



TURBO SALT SALT ELECTROLYSER

Salt treatment has never been this compact

- ↳ Ultra compact & easy install
- ↳ 4 operating modes + 2 Boost modes
- ↳ Compatible with all above ground and in ground swimming pools
- ↳ Low salinity 3g/L
- ↳ Cell guaranteed "Long Life" 7 000h

WARRANTY
Control panel + Cell

3
YEARS

6 VERSIONS AVAILABLE

6 operating modes

Cover	Spring	Summer	Comfort	Boost	Boost ++
25%	50%	75%	100%	150%	300%

A concentrate of technologies for naturally healthy water.

Salt electrolysis, for a healthy pool, without chemicals.

Whether for an above-ground pool or an in-ground pool, treatment by salt electrolysis has many advantages, starting with the financial aspect.

Without the indispensable chlorine tablets, you load your water with sea salt at a rate of 3g per litre of water. The electrolyser generates chlorine from the salt in the water. Once its disinfecting action is complete, the chlorine becomes salt again. The Turbo Salt runs a true virtuous circle.

Available for pools from 10 to 80m³, the Turbo Salt is supplied with 50mm (1' 1/2) and 32/38mm connections. Supplied with a wall or floor support, this electrolyser adapts to all types of filtration and its ultra-compact size allows it to be installed in the smallest technical rooms.

Apart from the economic aspect, salt water chlorination has many other advantages. No more chemical odours and no more storage of chlorine tablets. Its use is also simplified as chlorine production is controlled from the touch of a button based on weather conditions and pool usage.

This type of treatment is much gentler to the skin, eyes, hair and mucous membranes, especially for people prone to irritation.

With Turbo Salt, you can keep your pool fresh longer: by using fewer chemicals, you avoid the stabiliser saturation of chlorine tablets.

Did you know?

The salt content of seawater is around 34g/L of water, whereas an electrolyser operates at 3g/L.

Accessories included

2x 50mm connections
to glue



2x 32/ 38mm connections



10 mA differential
power socket



Fixation support
multi-positions

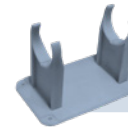

Intuitive use

- On/Off
- Water temperature & production level
- Change operating mode
- "Super Boost" mode
- Low salt level alarm

Use made easy

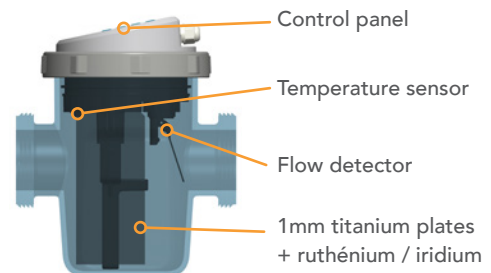

2 compact dimensions

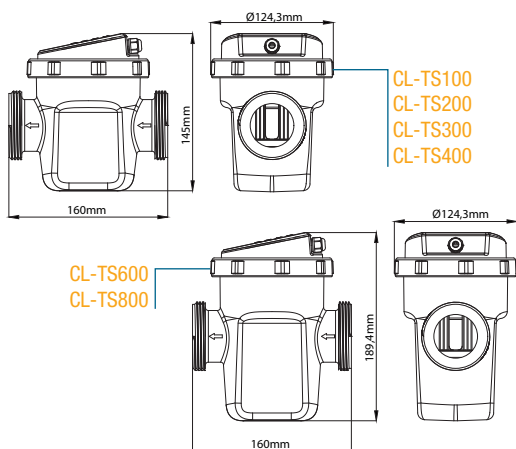

Reference	CL-TS100	CL-TS200	CL-TS300	CL-TS400	CL-TS600	CL-TS800
Pool volume (m ³)	10	20	30	40	60	80
Production g/h	2	4	6	8	12	18
Connection	50mm to glue / adapters 32/38mm					
Salinity	3,5ppm					
Protection	IPX4					
Closed pool mode	Yes, manual					
Self-cleaning	With reverse polarity					
Alarms	Too much / not enough salt, water flow not fast enough					
Cell orientation	Horizontal or vertical					
Box dimensions	125 x 160 x 145 mm			125 x 160 x 190 mm		
Cell dimensions	Length 40cm with connectors - DN 50mm					
Modes	Automatic / Winterizing / Shock Chlorine					
Warranty	3 years: control panel + cell 7,000h					